

# DHL Pumps

**PETER KING TRADING**

21 Beach Avenue

Mordialloc VIC 3195

AUSTRALIA

Ph (03) 9587 4874 Fax (03) 9587 4709

[www.peterkingtrading.com.au](http://www.peterkingtrading.com.au)

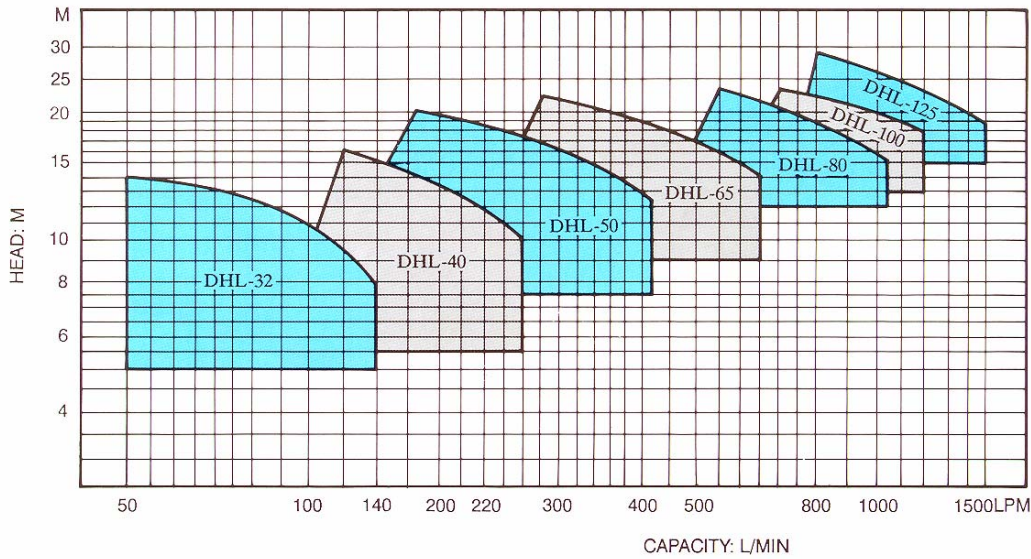

MODEL	MOTOR (3 PH)			PUMP					SUITABLE FOR COOLING TOWER MODEL
	H.P.	POLE	VOLT	BORE mm (in)	HEAD M	CAP L/MIN	HEAD M	CAP L/MIN	
DHL-32	1/2	2	415	32 (1 1/4")	14	50	11	110	5-10
DHL-40	1	2	415	40 (1 1/2")	16	120	12	235	15-20
DHL-50	2	2	415	50 (2")	20	180	15	340	25-30
DHL-65	3	2	415	60 (2 1/2")	22	280	17	500	40-50
DHL-80	5	2	415	80 (3")	23	550	16	1000	60-90
DHL-100	7 1/2	2	415	100 (4")	23	700	18	1200	80-100
DHL-125	10	2	415	100 (4")	29	800	20	1400	100-125

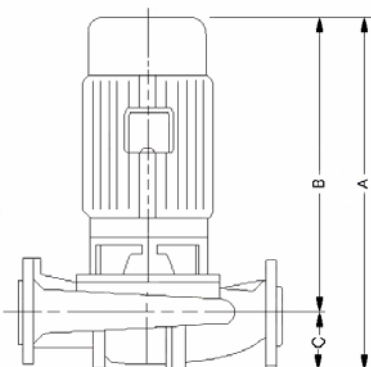
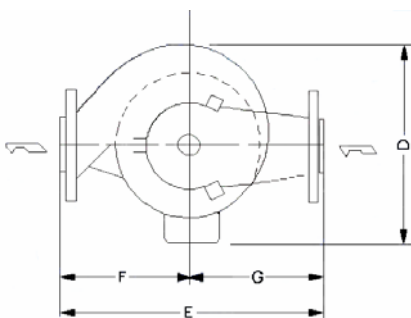

MODEL	DIMENSION (mm)							WEIGHT KG
	A	B	C	D	E	F	G	
DHL-32	340	270	70	230	310	155	155	19
DHL-40	410	330	80	250	340	170	170	28
DHL-50	440	360	80	260	370	185	185	33
DHL-65	480	390	90	295	390	195	195	48
DHL-80	520	422	98	310	400	200	200	53
DHL-100	590	475	115	370	460	230	230	96
DHL-125	620	480	115	370	460	230	230	119